

Innovative Technology
Sincere Service

Passion ♦ Integrity
Technology ♦ Speciality



SMALL HOUSEHOLD APPLIANCE MOTOR

Electric fan motor
Range hood motor
Washing machine motor
Freezer motor



Guangzhou SunChongLic Electric Appliance Co.,Ltd

Sales Center

Add:Unit 1118-1120, No.219, Zhongshan 5th Road, Cts Center, Yuexiu District, Guangzhou, Guangdong Province, China. (Metro: Exit A or B, Gong Yuan Qian Station, Subway Line 1 or Line 2)

Mobile/WhatsApp/WeChat: +86-13711271181

E-Mail: factory01@sunchonglic.com

Tel: +86-20-83230279 **Fax:** +86-20-83185458

Web: www.sunchonglic.com

MADE IN CHINA



@sunchonglic



Alibaba



Alibaba



Facebook



Official Web

GUANGZHOU SUNCHONGLIC ELECTRIC APPLIANCE CO.,LTD



Company Introduction

Established in 2015, located in Foshan city, Guangdong province, China. Guangzhou Sunchonglic Electric Appliance Co., Ltd. is mainly dealing with home appliance accessories. With unique and innovative design, low interference technology, and performance -to -price ratio. With more than 10, 000 square meters logistics center, nowadays, our products are exported to more than 2 00 countries in the world and regions.

We have a manufacture factory continually supplying with power inverter, Gel/AGM battery charger, PWM/MPPT solar charge controller, and fan motor (OEM & ODM), LCD wall mount, Power cord, RVV cable, PCB power board, washing machine parts, air conditioning parts, induction cooker parts, microwave oven parts, etc. With well-equipped testing facilities and strong technical force, in the near future, we will mainly focus on the intelligent solar green energy.

With a wide range of applications, reasonable prices and stylish designs, our products are extensively used in home appliance accessories and other industries. Our products are widely recognized and trusted by our clients and can meet continuously changing economic and social needs. A primary strategy is superior customer satisfaction. We will constantly analyze market needs around the world to develop a full range of products for business, industry, and clean energy.

We are re-engineering our information systems throughout economic global integration to meet modern advanced standards. We would sincerely welcome new and old customers from over the world to visit and contact us for future business relationships and mutual success!

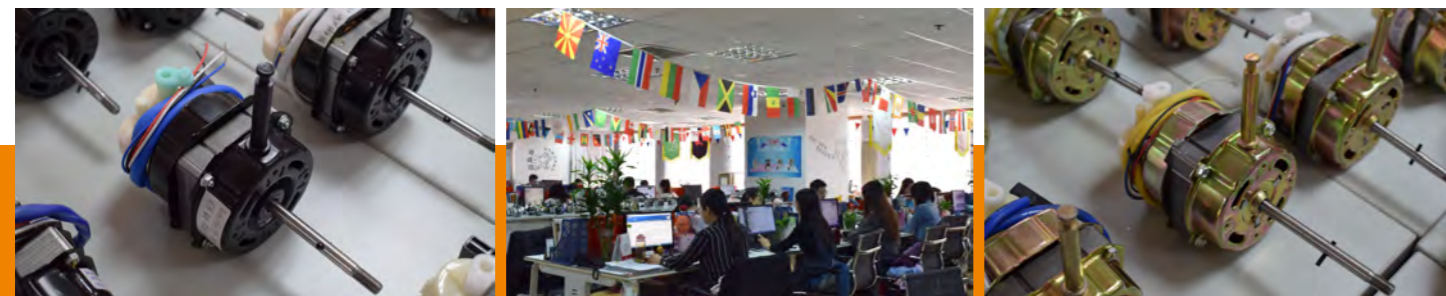

Domestic and international exhibitions



Motor Factory



Warehouse Logistics





CONTENTS

Electric fan motor P01-12

Table fan/Wall fan/Orbit fan/Business fan/Industrial pedestal fan/Box fan/Floor fan/Exhaust fan/Bathroom

Range hood motor P13-16

Washing machine motor P17-23

Washing motor/Dewatering motor/Full automatic motor

Freezer motor P24-26

Choose Sunchonglic Fan Motor

High compactness of fan motor components enables the motor to run stably. High-quality coils are Strong and ductile, durable and non-aging, which is more efficient. Save money and no worries.

Strong Structure
X
Durable



Four Features Can Guarantee Purchase And Usages



Copper wire coil

Strong suction power
More resistant to heat
High rotating speed
Long service life



Thickened stator

Can protect the internal structure of the motor and to ensure the stability of motor performances



Run smoothly

Adopt quality lubricating oil, reduce resistance for motor, high rotating speed



Strong power

Stronger rotor, higher speed, larger air volume delivery



Table fan motor



Wall fan motor



Orbit fan motor



Business fan motor



Industrial pedestal fan motor

Table Fan Motor

Fan motor components have high tightness that enables the motor stable during operation. High-quality coils are tough, not easily broken, durable and non-aging, which is more efficient. Save money, and worry!

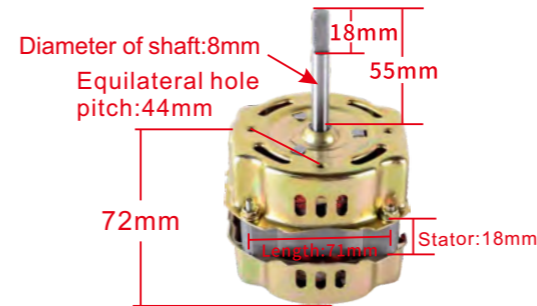

Product categories: Table fan motor

Special research and development for Bangladesh

Model NO.	B06010066
Stator	71*18
Winding material	Aluminum winding
Weight	0.85kg

Product parameters

Number of lines	2 lines & 1 gears	Working voltage	220v 50Hz
Rotating speed	2200r/min	Capacitor	1.8μF/450V
Packed QTY	20 pcs/ctn	Peak power	62W

Long shaft

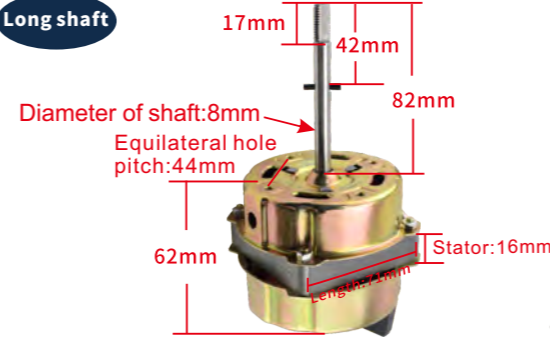

Product categories: Table fan motor

Special research and development for Bangladesh

Model NO.	B06010269
Stator	71*16
Winding material	Aluminum winding
Weight	0.8kg

Product parameters

Number of lines	2 lines & 1 gears	Working voltage	220v 50Hz
Rotating speed	2200r/min	Capacitor	1.5μF/450V
Packed QTY	20 pcs/ctn	Peak power	45W

Long shaft

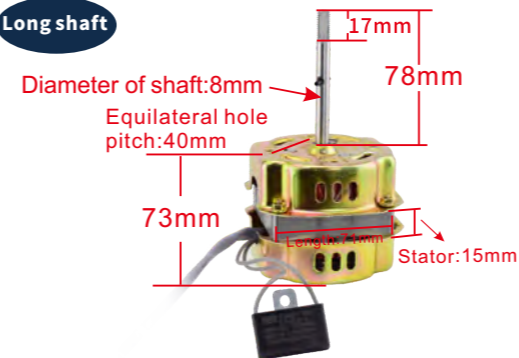

Product categories: Table fan motor

Special research and development for Bangladesh

Model NO.	B06010284
Stator	71*15
Winding material	Aluminum winding
Weight	0.75kg

Product parameters

Number of lines	2 lines & 1 gears	Working voltage	220v 50Hz
Rotating speed	1200-1250r/min	Capacitor	1.5μF/450V
Packed QTY	20 pcs/ctn	Peak power	45W

Long shaft

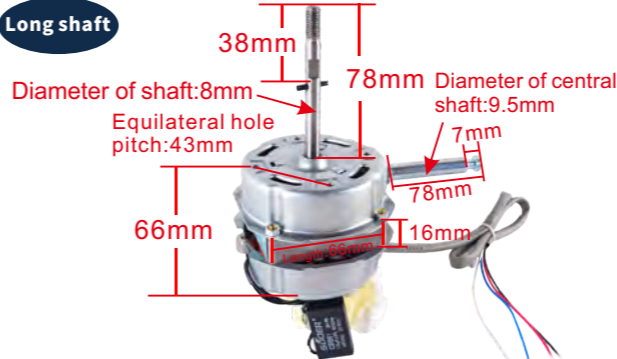

Product categories: Table fan motor

Special research and development for Bangladesh

Model NO.	B06010120
Stator	66*16
Winding material	Aluminum winding
Weight	0.89kg

Product parameters

Number of lines	4 lines & 3 gears	Working voltage	220v 50Hz
Rotating speed	1200r/min	Capacitor	1.5μF/450V
Packed QTY	20 pcs/ctn	Peak power	55W

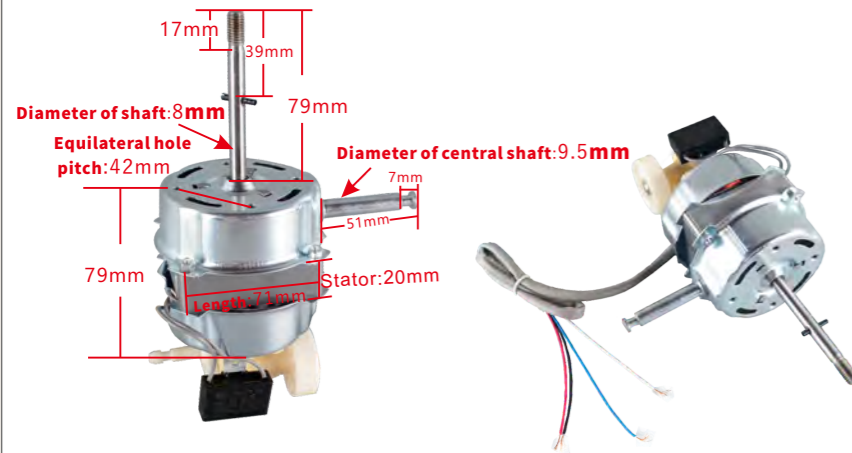

Product categories: Table fan motor

Model NO.	B06010212
Stator	71*20
Winding material	Aluminum winding
Weight	1.02kg

Product parameters

Number of lines	4 lines & 3 gears	Working voltage	220v 50Hz
Rotating speed	1200r/min	Capacitor	1.5μF/450V
Packed QTY	20 pcs/ctn	Peak power	55W



Product categories: Table fan motor • 608 bearing

Model NO.	B06010221	B06010222	B06010254
Stator	71*20	71*22	71*22
Winding material	Copper winding		
Weight	1.10kg	1.15kg	1.15kg

Product parameters

Number of lines	4 lines & 3 gears	Working voltage	220v 50Hz
Rotating speed	1250r/min	Capacitor	1.5μF/450V
Packed QTY	20 pcs/ctn	Peak power	60W

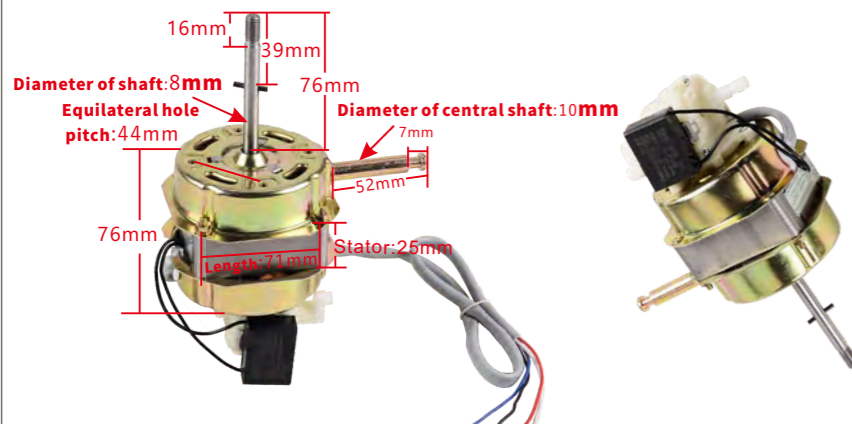

Product categories: Table fan motor

Model NO.	B06010286
Stator	71*25
Winding material	Copper winding
Weight	1.28kg

Product parameters

Number of lines	2 lines & 1 gears	Working voltage	220v 50Hz
Rotating speed	1275r/min	Capacitor	2.0μF/450V
Packed QTY	20 pcs/ctn	Peak power	45W



Product categories: Table fan motor • 608 bearing

Model NO.	B06010226	B06010227	B06010228
Stator	71*14	71*18	71*20
Winding material	Copper winding		
Weight	0.85kg	0.9kg	0.97kg

Product parameters

Number of lines	4 lines & 3 gears	Working voltage	220v 50Hz
Rotating speed	1250r/min	Capacitor	1.5μF/450V
Packed QTY	20 pcs/ctn	Peak power	60W

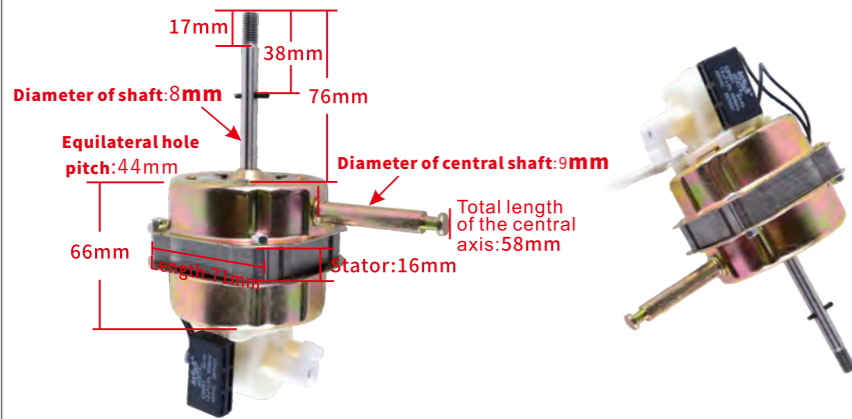

Product categories: Table fan motor

Model NO.	B06010186
Stator	71*16
Winding material	Aluminum winding
Weight	0.89kg

Product parameters

Number of lines	4 lines & 3 gears	Working voltage	220v 50Hz
Rotating speed	1200r/min	Capacitor	1.5μF/450V
Packed QTY	20 pcs/ctn	Peak power	55W

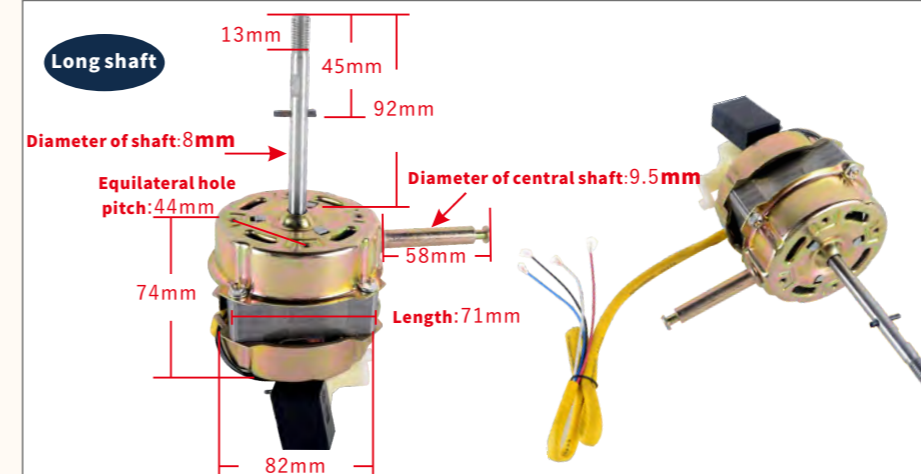

Product categories: Table fan motor

Model NO.	B06010237	B06010238
Stator	71*22	71*22
Winding material	Copper winding	Aluminum winding
Weight	1.14kg	1.08kg

Product parameters

Number of lines	4 lines & 3 gears	Working voltage	220v 50Hz
Rotating speed	1200r/min	Capacitor	1.5μF/450V
Packed QTY	20 pcs/ctn	Peak power	55W

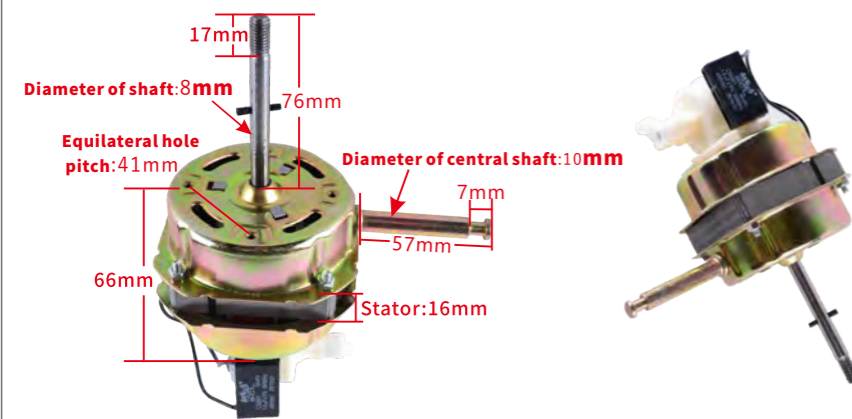

Product categories: Table fan motor

Model NO.	B06010190
Stator	66*16
Winding material	Copper winding
Weight	0.95kg

Product parameters

Number of lines	4 lines & 3 gears	Working voltage	220v 50Hz
Rotating speed	1200r/min	Capacitor	1.5μF/450V
Packed QTY	20 pcs/ctn	Peak power	55W

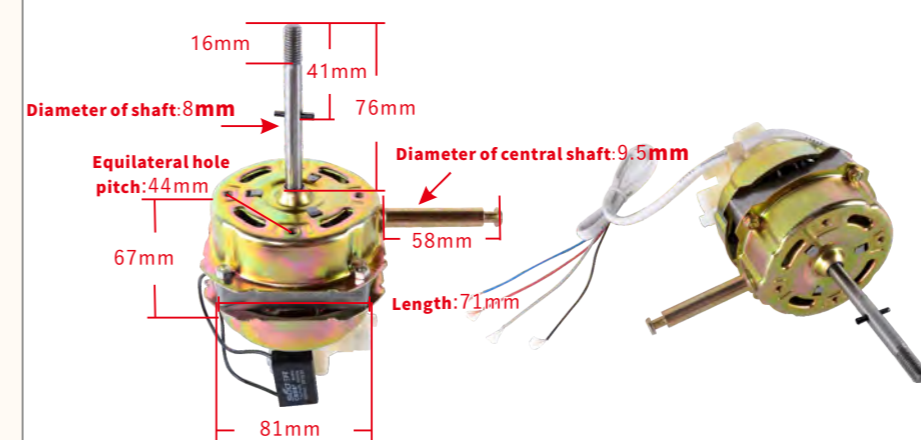

Product categories: Table fan motor

Model NO.	B06010245	B06010246	B06010249	B06010252
Stator	71*14	71*16	71*18	71*20
Winding material	Aluminum winding	Copper winding		
Weight	0.81kg	0.93kg	1kg	1.05kg

Product parameters

Number of lines	4 lines & 3 gears	Working voltage	220v 50Hz
Rotating speed	1200r/min	Capacitor	1.5μF/450V
Packed QTY	20 pcs/ctn	Peak power	55W

Product categories: Table fan motor

Model NO.	B06010173		
Stator	71*25		
Winding material	Copper winding		
Weight	1.25kg		

Product parameters			
Number of lines	4 lines & 3 gears	Working voltage	220v 50Hz
Rotating speed	1250r/min	Capacitor	2 μ F/450V
Packed QTY	20 pcs/ctn	Peak power	60W

Product categories: Table fan motor • 608 bearing

• Power cord with synchronous motor

Model NO.	B06010264	B06010265	B06010266	B06010267
Stator	71*16	71*18	71*20	71*22
Winding material	Copper winding			
Weight	0.92kg	0.99kg	1.06kg	1.13kg

Product parameters			
Number of lines	5 lines & 3 gears	Working voltage	220v 50Hz
Rotating speed	1250r/min	Capacitor	1.5 μ F/450V
Packed QTY	20 pcs/ctn	Peak power	60W

Product categories: Table fan motor

Model NO.	B06010174		
Stator	74*25		
Winding material	Aluminum winding		
Weight	1.25kg		

Product parameters			
Number of lines	4 lines & 3 gears	Working voltage	220v 50Hz
Rotating speed	1200r/min	Capacitor	1.5 μ F/450V
Packed QTY	20 pcs/ctn	Peak power	55W

Product categories: Table fan motor

Model NO.	B06010220		
Stator	71*22		
Winding material	Copper winding		
Weight	1.13kg		

Product parameters			
Number of lines	4 lines & 3 gears	Working voltage	220v 50Hz
Rotating speed	1250r/min	Capacitor	1.8 μ F/450V
Packed QTY	20 pcs/ctn	Peak power	60W

Product categories: Table fan motor • 3 in 1

Model NO.	B06010331		
Stator	98*14		
Winding material	Aluminum winding		
Weight	1.4kg		

Product parameters			
Number of lines	4 lines & 3 gears	Working voltage	220v 50Hz
Rotating speed	1250r/min	Capacitor	1.8 μ F/450V
Packed QTY	20 pcs/ctn	Peak power	60W

Product categories: Orbit fan motor

Model NO.	B06010213		
Stator	71*20		
Diameter of axle	Small shaft		
Weight	1.15kg		
Winding material	Copper winding		

Product parameters			
Number of lines	4 lines & 1 gears	Working voltage	220v 50Hz
Rotating speed	1200r/min	Capacitor	1.5 μ F/400V
Packed QTY	20 pcs/ctn	Peak power	55W

Product categories: Table fan motor

Model NO.	B06010018		
Stator	98*20		
Winding material	Aluminum winding		
Weight	1.8kg		

Product parameters			
Number of lines	5 lines & 3 gears	Working voltage	220v 50Hz
Rotating speed	1200r/min	Capacitor	2.5 μ F/450V
Packed QTY	20 pcs/ctn	Peak power	50W

Product categories: Orbit fan motor

Model NO.	B06010214		
Stator	74*20		
Diameter of axle	Big shaft		
Weight	1.35kg		
Winding material	Copper winding		

Product parameters			
Number of lines	4 lines & 1 gears	Working voltage	220v 50Hz
Rotating speed	1200r/min	Capacitor	1.5 μ F/400V
Packed QTY	20 pcs/ctn	Peak power	55W

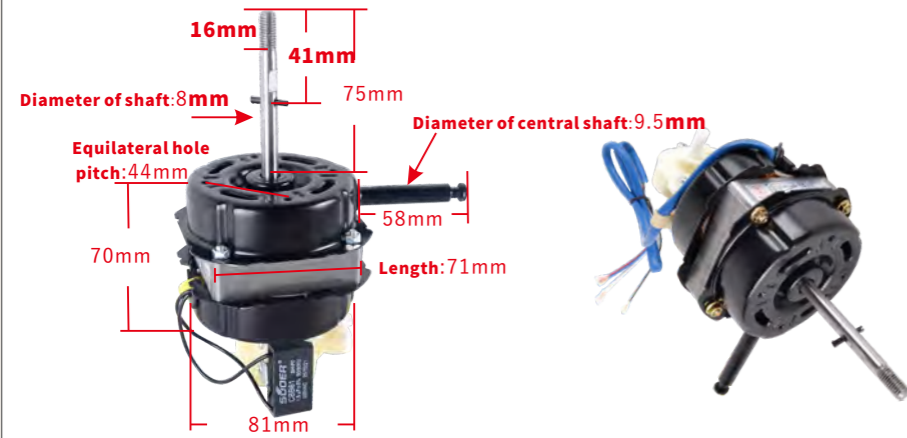

Product categories: Table fan motor • 608 bearing

Model NO.	B06010248	B06010251	B06010253
Stator	71*16	71*18	71*20
Winding material	Copper winding		
Weight	0.93kg	0.99kg	1.05kg

Product parameters

Number of lines	4 lines & 3 gears	Working voltage	220v 50Hz
Rotating speed	1250r/min	Capacitor	1.5μF/450V
Packed QTY	20 pcs/ctn	Peak power	60W

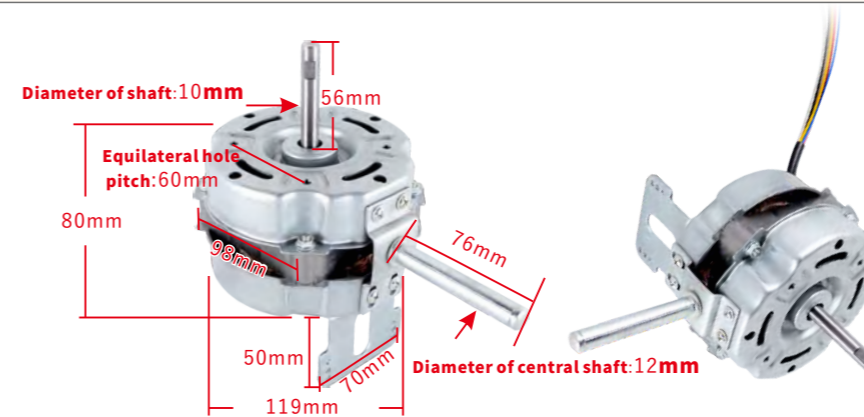

Product categories: Business fan motor

• Double bearing

Model NO.	B06010170
Stator	98*20
Winding material	Copper winding
Weight	2.15kg

Product parameters

Number of lines	5 lines & 3 gears	Working voltage	220v 50Hz
Rotating speed	1350r/min	Capacitor	3μF
Packed QTY	12 pcs/ctn	Peak power	140W



Product categories: Wall fan motor • 608 bearing

Model NO.	B06010223	B06010224	B06010225
Stator	71*16	71*18	71*20
Winding material	Aluminum winding		
Weight	0.89kg	0.92kg	0.95kg

Product parameters

Number of lines	4 lines & 3 gears	Working voltage	220v 50Hz
Rotating speed	1250r/min	Capacitor	1.5μF/450V
Packed QTY	20 pcs/ctn	Peak power	60W

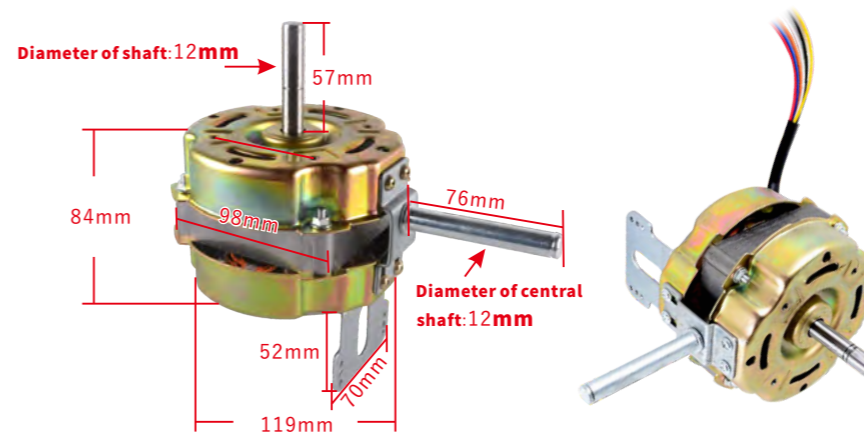

Product categories: Business fan motor

• Double bearing

Model NO.	B06010171
Stator	98*24
Winding material	Copper winding
Weight	2.5kg

Product parameters

Number of lines	6 lines & 4 gears	Working voltage	220v 50Hz
Rotating speed	1350r/min	Capacitor	3μF
Packed QTY	12 pcs/ctn	Peak power	150W

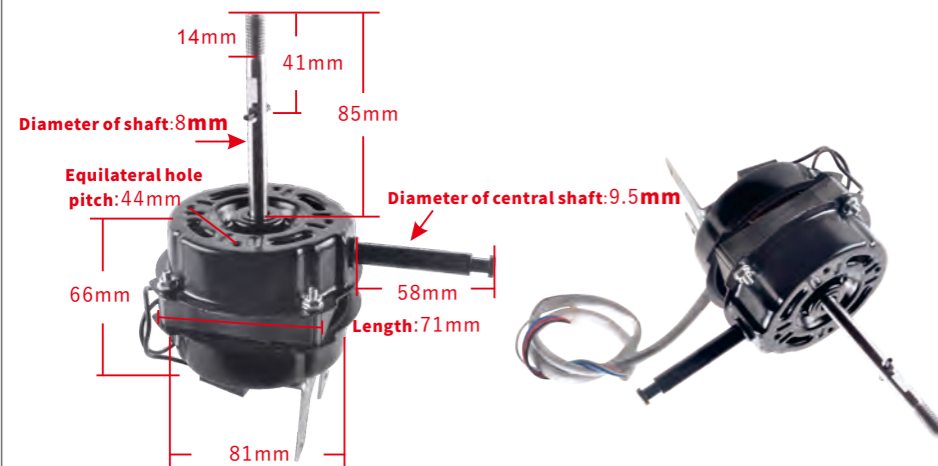

Product categories: Wall fan motor • 608 bearing

Model NO.	B06010132
Stator	71*16
Winding material	Copper winding
Weight	0.9kg

Product parameters

Number of lines	4 lines & 3 gears	Working voltage	220v 50Hz
Rotating speed	1250r/min	Capacitor	1.5μF/450V
Packed QTY	20 pcs/ctn	Peak power	60W



Product categories: Industrial pedestal fan motor

Model NO.	B07010001
Winding material	Copper winding
Color	Black green
Specification	450mm

Product parameters

Rotating speed	1400r/min	Working voltage	220v 50Hz
Packed QTY	5 pcs/ctn	Peak power	260W
Weight	2.6kg		

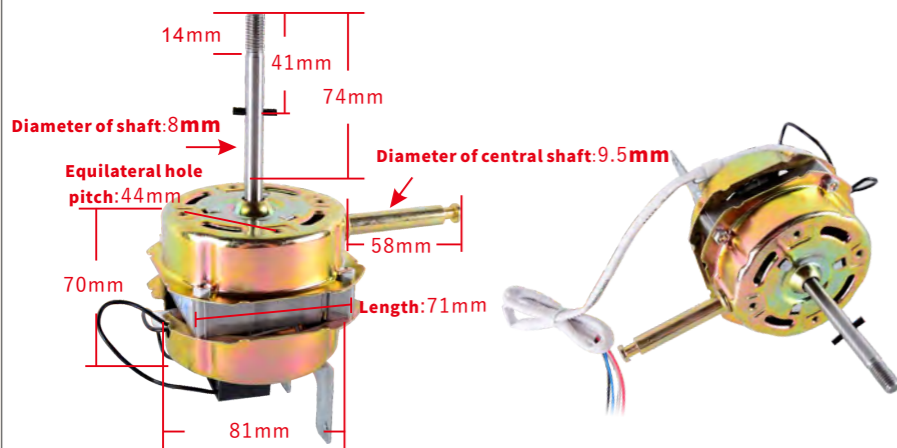

Product categories: Wall fan motor

Model NO.	B06010240	B06010241	B06010236
Stator	71*16	71*18	71*20
Winding material	Copper winding		
Weight	0.9kg	0.98kg	1.04kg

Product parameters

Number of lines	4 lines & 3 gears	Working voltage	220v 50Hz
Rotating speed	1200r/min	Capacitor	1.5μF/450V
Packed QTY	20 pcs/ctn	Peak power	55W



Product categories: Industrial pedestal fan motor

Model NO.	B07010007
Winding material	Copper winding
Color	Black green
Specification	750mm

Product parameters

Rotating speed	1400r/min	Working voltage	220v 50Hz
Packed QTY	2 pcs/ctn 6 big pcs/ctn	Peak power	280W
Weight	3.2kg		



Model No. B06010019
Box fan 12 inches revealed-16mm (45W Blue 6 wires)(Copper)

Product parameters

Winding material	Copper winding	Working voltage	220v 50Hz
Number of lines	6 lines & 3 gears	Peak power	45W
Capacitor (Optional)	1μF/450V	Rotating speed	1230r/min
Packed QTY	30pcs/ctn	Weight	0.86kg

Model No. B06010155
Floor fan motor-12 inches (Pure copper black shell)

Product parameters

Winding material	Copper winding	Working voltage	220v 50Hz
Number of lines	5 lines & 3 gears	Peak power	55W
Capacitor (Optional)	1.5μF/450V	Rotating speed	1350r/min
Packed QTY	20pcs/ctn	Weight	0.89kg

Model No. B06010091
Box fan 10 inches revealed-10mm (45W Blue 6 wires)(Copper)

Product parameters

Winding material	Copper winding	Working voltage	220v 50Hz
Number of lines	6 lines & 3 gears	Peak power	45W
Capacitor (Optional)	1μF/450V	Rotating speed	1230r/min
Packed QTY	30pcs/ctn	Weight	0.6kg

Model No. B06010182
Floor fan motor-14 inches (Pure copper bearing black shell)

Product parameters

Winding material	Copper winding	Working voltage	220v 50Hz
Number of lines	5 lines & 3 gears	Peak power	65W
Capacitor (Optional)	2μF/450V	Rotating speed	1350r/min
Packed QTY	20pcs/ctn	Weight	1.3kg

Double bearing

Model No. B06010090
Box fan 10 inches revealed-10mm (38W Blue 5 wires)(Copper black outer shell)

Product parameters

Winding material	Copper winding	Working voltage	220v 50Hz
Number of lines	5 lines & 3 gears	Peak power	38W
Capacitor (Optional)	1.2μF/450V	Rotating speed	1230r/min
Packed QTY	30pcs/ctn	Weight	0.6kg

Model No. B06010217
Floor fan motor-16 inches (Pure copper black shell)

Product parameters

Winding material	Copper winding	Working voltage	220v 50Hz
Number of lines	5 lines & 3 gears	Peak power	160W
Capacitor (Optional)	4μF/450V	Rotating speed	1350r/min
Packed QTY	12pcs/ctn	Weight	2.35kg

Double bearing

Model No. B06010093
Box fan 12 inches revealed-14mm (45W Yellow 5 wires)(Copper black outer shell)

Product parameters

Winding material	Copper winding	Working voltage	220v 50Hz
Number of lines	5 lines & 3 gears	Peak power	45W
Capacitor (Optional)	1.2μF/450V	Rotating speed	1230r/min
Packed QTY	30pcs/ctn	Weight	0.75kg

Model No. B06010218
Floor fan motor-18 inches (Pure copper black shell)

Product parameters

Winding material	Copper winding	Working voltage	220v 50Hz
Number of lines	5 lines & 3 gears	Peak power	170W
Capacitor (Optional)	4μF/450V	Rotating speed	1350r/min
Packed QTY	12pcs/ctn	Weight	

Double bearing

Model No. B06010219
Floor fan motor-20 inches (Pure copper black shell)

Product parameters

Winding material	Copper winding	Working voltage	220v 50Hz
Number of lines	5 lines & 3 gears	Peak power	180W
Capacitor (Optional)	5μF/450V	Rotating speed	1350r/min
Packed QTY	12pcs/ctn		

Double bearing

Double ball bearing
Effectively reduce motor heating
High speed and low noise
Anti Wear Durability
Work smoothly without resistance

Model No. B06010080
Exhaust fan-12 inches 14mm whole sealing (45W Back 3 wires)(Copper)

Product parameters

Winding material	Copper winding	Working voltage	220v 50Hz
Number of lines	3 lines	Peak power	45W
Capacitor (Optional)	1.2μF/450V	Rotating speed	1250r/min
Packed QTY	28pcs/ctn	Weight	0.72kg

Model No. B06010161
Exhaust fan-12 inches 14mm black shell whole sealing (45W Back 3 wires)(Copper) Bearing

Product parameters

Winding material	Copper winding	Working voltage	220v 50Hz
Number of lines	3 lines	Peak power	45W
Capacitor (Optional)	1.2μF/450V	Rotating speed	1250r/min
Packed QTY	28pcs/ctn	Weight	0.73kg

Model No. B06010165
Exhaust fan-12 inches 14mm revealed (45W Back 3 wires)(Copper)

Product parameters

Winding material	Copper winding	Working voltage	220v 50Hz
Number of lines	3 lines	Peak power	45W
Capacitor (Optional)	1.2μF/450V	Rotating speed	1250r/min
Packed QTY	28pcs/ctn	Weight	0.61kg

Model No. B06010165
Exhaust fan-12 inches 14mm revealed (45W Back 3 wires)(Copper)

Product parameters

Winding material	Copper winding	Working voltage	220v 50Hz
Number of lines	3 lines	Peak power	45W
Capacitor (Optional)	1.2μF/450V	Rotating speed	1250r/min
Packed QTY	28pcs/ctn	Weight	0.61kg

Model No. B28040154
Bathroom-30Motor-Positive and negative rotation (Shaft length 4.5cm)Copper coil

Product parameters

Winding material	Copper winding	Working voltage	220v 50Hz
Number of lines	3 lines	Peak power	7W
Capacitor (Optional)	1μF/450V	Rotating speed	1250r/min
Packed QTY	20pcs/ctn	Weight	0.46kg

Model No. B28040191
Bathroom-30Motor-Positive and negative rotation (Shaft length 4.5cm)Copper coil

Product parameters

Winding material	Copper winding	Working voltage	220v 50Hz
Number of lines	3 lines	Peak power	7W
Capacitor (Optional)	1μF/450V	Rotating speed	1250r/min
Packed QTY	20pcs/ctn	Weight	0.50kg

Model No. B28040192
Bathroom-30Motor-Positive and negative rotation (Shaft length 3.2cm)Copper coil

Product parameters

Winding material	Copper winding	Working voltage	220v 50Hz
Number of lines	3 lines	Peak power	7W
Capacitor (Optional)	1μF/450V	Rotating speed	1250r/min
Packed QTY	20pcs/ctn	Weight	0.51kg

Wiring diagram

Bathroom Ventilation fan motor

Model No. B28040191
Bathroom-30Motor-Positive and negative rotation (Shaft length 4.5cm)Copper coil

Product parameters

Winding material	Copper winding	Working voltage	220v 50Hz
Number of lines	3 lines	Peak power	7W
Capacitor (Optional)	1μF/450V	Rotating speed	1250r/min
Packed QTY	20pcs/ctn	Weight	0.50kg

Model No. B28040192
Bathroom-30Motor-Positive and negative rotation (Shaft length 3.2cm)Copper coil

Product parameters

Winding material	Copper winding	Working voltage	220v 50Hz
Number of lines	3 lines	Peak power	7W
Capacitor (Optional)	1μF/450V	Rotating speed	1250r/min
Packed QTY	20pcs/ctn	Weight	0.51kg

Model No. B28040232
Bathroom-40Motor-Positive and negative rotation (Shaft length 3.1cm)Copper coil

Product parameters

Winding material	Copper winding	Working voltage	220v 50Hz
Number of lines	3 lines	Peak power	10W
Capacitor (Optional)	1μF/450V	Rotating speed	1250r/min
Packed QTY	20pcs/ctn	Weight	0.70kg

Model No. B28040232
Bathroom-40Motor-Positive and negative rotation (Shaft length 3.1cm)Copper coil

Product parameters

Winding material	Copper winding	Working voltage	220v 50Hz
Number of lines	3 lines	Peak power	10W
Capacitor (Optional)	1μF/450V	Rotating speed	1250r/min
Packed QTY	20pcs/ctn	Weight	0.70kg

Model No. B28040232
Bathroom-40Motor-Positive and negative rotation (Shaft length 3.1cm)Copper coil

Product parameters

Winding material	Copper winding	Working voltage	220v 50Hz
Number of lines	3 lines	Peak power	10W
Capacitor (Optional)	1μF/450V	Rotating speed	1250r/min
Packed QTY	20pcs/ctn	Weight	0.70kg

Model No. B28040232
Bathroom-40Motor-Positive and negative rotation (Shaft length 3.1cm)Copper coil

Product parameters

Winding material	Copper winding	Working voltage	220v 50Hz
Number of lines	3 lines	Peak power	10W
Capacitor (Optional)	1μF/450V	Rotating speed	1250r/min
Packed QTY	20pcs/ctn	Weight	0.70kg

Model No. B28040232
Bathroom-40Motor-Positive and negative rotation (Shaft length 3.1cm)Copper coil

Product parameters

Winding material	Copper winding	Working voltage	220v 50Hz
Number of lines	3 lines	Peak power	10W
Capacitor (Optional)	1μF/450V	Rotating speed	1250r/min
Packed QTY	20pcs/ctn	Weight	0.70kg

Model No. B28040232
Bathroom-40Motor-Positive and negative rotation (Shaft length 3.1cm)Copper coil

Product parameters

Winding material	Copper winding	Working voltage	220v 50Hz
Number of lines	3 lines	Peak power	10W
Capacitor (Optional)	1μF/450V	Rotating speed	1250r/min
Packed QTY	20pcs/ctn	Weight	0.70kg

STRONG QUIET

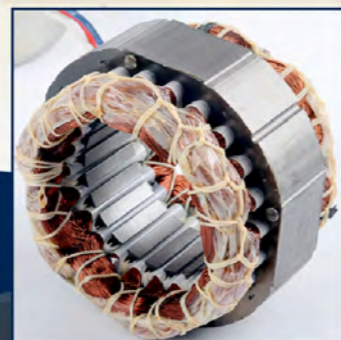

Copper wire winding



Smooth operation

Range hood motor

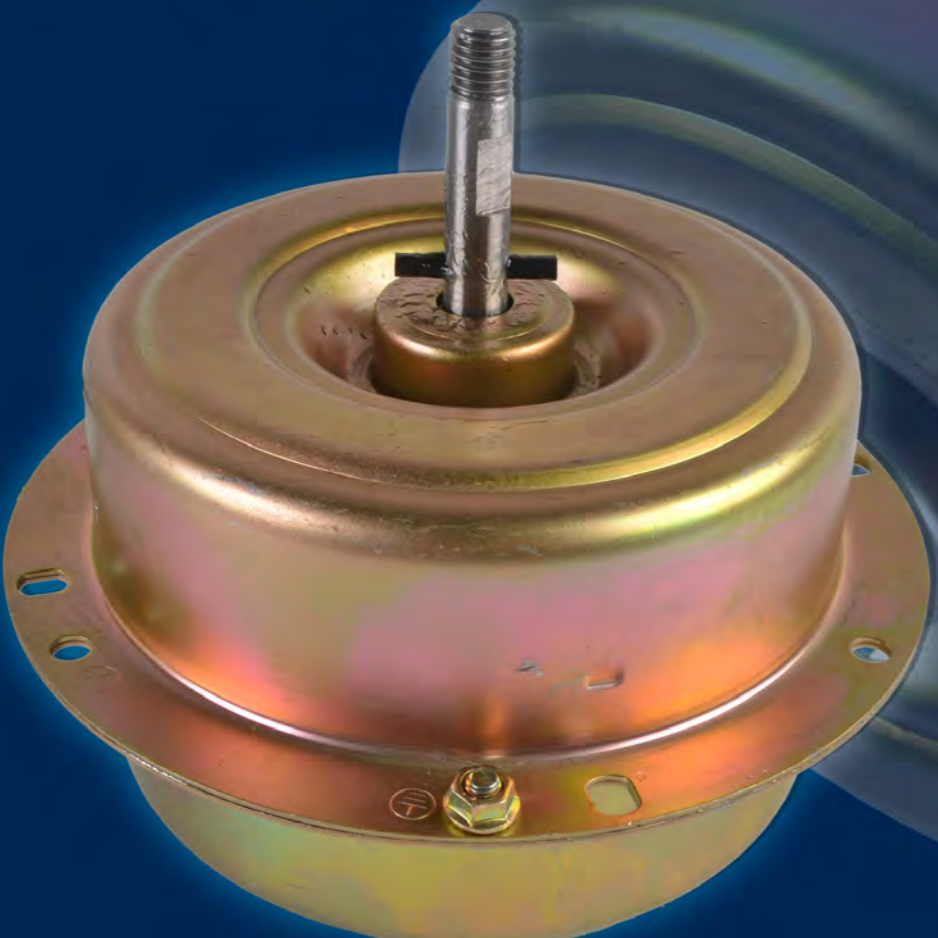

- HIGH POWER
- DOUBLE BALL BEARINGS
- GENERAL MODELS
- PURE COPPER COILS
- ENCLOSED DESIGN
- PRECISION MACHINING

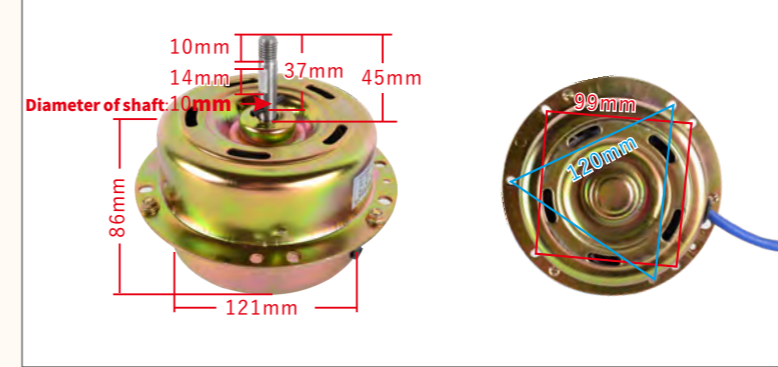

Model No. B1901002

Range Hood Motor-16mm 180w (Open pore double bearing)

Product parameters			
Winding material	Aluminum winding	Working voltage	220v 50Hz
Number of lines	4 lines & 2 gears	Peak power	180W
Capacitor (Optional)	4μF/450V	Rotating speed	1200r/min
Stator	108*16	Weight	1.75kg
Packed QTY	12pcs/ctn		

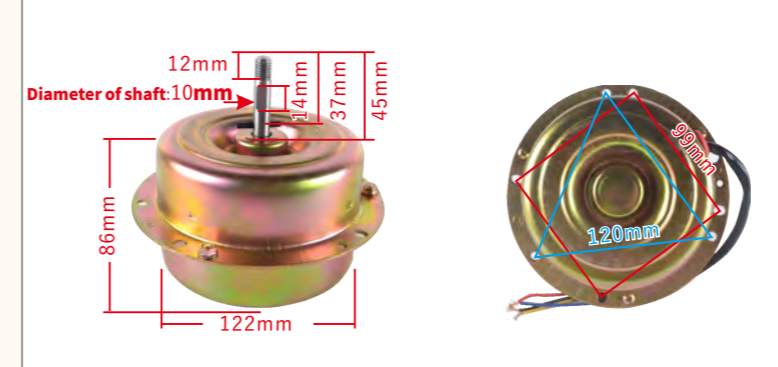

Model No. B19010022

Range Hood Motor-20mm 180w-10 axle whole sealing double bearing(Copper)-Positive rotation

Product parameters			
Winding material	Copper winding	Working voltage	220v 50Hz
Number of lines	4 lines & 2 gears	Peak power	180W
Capacitor (Optional)	4μF/450V	Rotating speed	1200r/min
Stator	108*20	Weight	2.2kg
Packed QTY	12pcs/ctn		

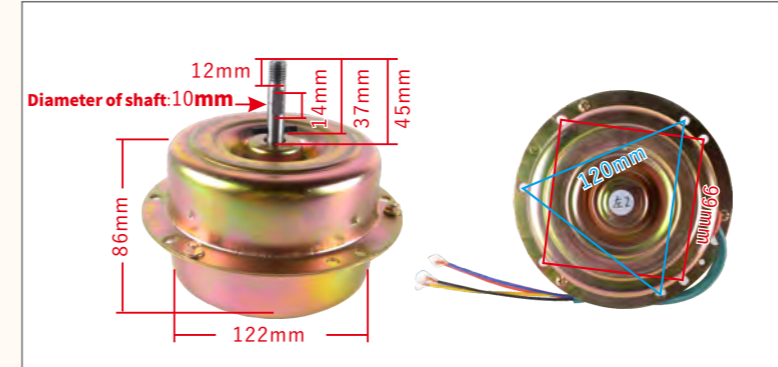

Model No. B19010025

Range Hood Motor-20mm 180w- whole sealing double bearing(Copper)-Negative rotation

Product parameters			
Winding material	Copper winding	Working voltage	220v 50Hz
Number of lines	4 lines & 2 gears	Peak power	180W
Capacitor (Optional)	4μF/450V	Rotating speed	1200r/min
Stator	108*20	Weight	2.31kg
Packed QTY	12pcs/ctn		

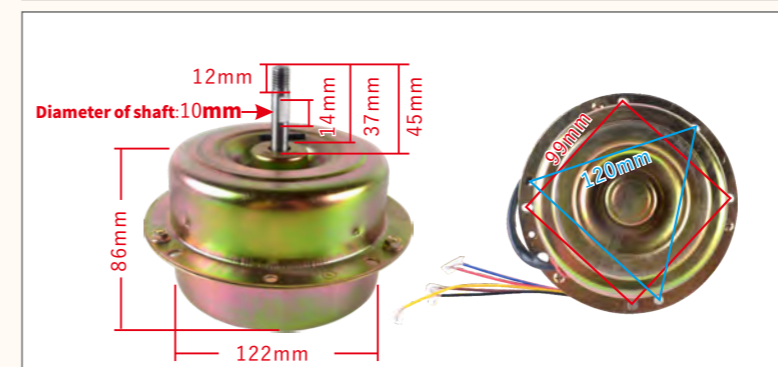

Model No. B19010027

Range Hood Motor-20mm 180w-whole sealing double bearing(Copper)-Positive rotation(5 lines&3 gears)

Product parameters			
Winding material	Copper winding	Working voltage	220v 50Hz
Number of lines	5 lines & 3 gears	Peak power	180W
Capacitor (Optional)	4μF/450V	Rotating speed	1200r/min
Stator	108*20	Weight	2.05kg
Packed QTY	12pcs/ctn		

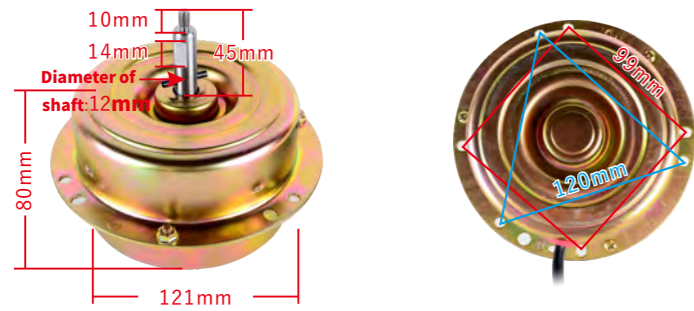

Model No. B19010032
Range Hood Motor-20mm 180w-12 axle whole sealing double bearing(Copper)-Positive rotation

Product parameters			
Winding material	Copper winding	Working voltage	220v 50Hz
Number of lines	4 lines & 2 gears	Peak power	180W
Capacitor (Optional)	4μF/450V	Rotating speed	1200r/min
Stator	108*20	Weight	2.32kg
Packed QTY	12pcs/ctn		

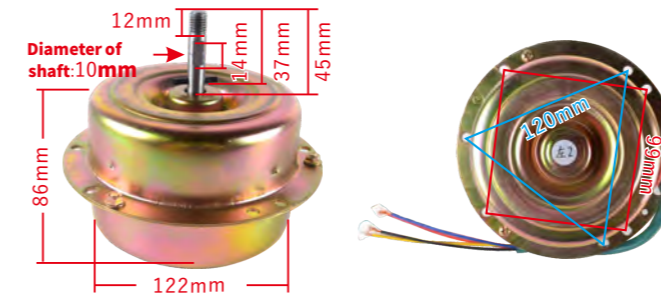

Model No. B19010029
Range Hood Motor-24mm 200w- whole sealing double bearing(Copper)

Product parameters			
Winding material	Copper winding	Working voltage	220v 50Hz
Number of lines	5 lines & 2 gears	Peak power	200W
Capacitor (Optional)	6μF/450V	Rotating speed	1300r/min
Stator	108*24	Weight	2.5kg
Packed QTY	12pcs/ctn		

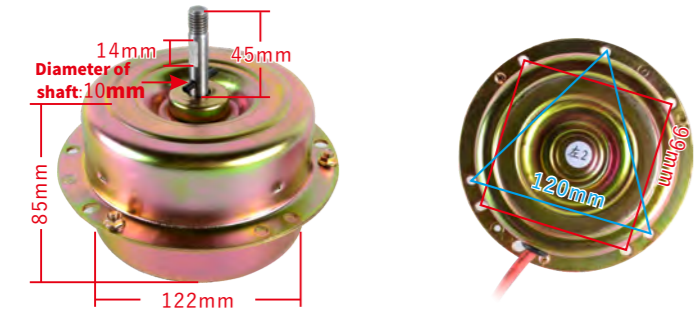

Model No. B19010031
Range Hood Motor-20mm 180w- whole sealing double bearing(Aluminum)-Negative rotation

Product parameters			
Winding material	Aluminum winding	Working voltage	220v 50Hz
Number of lines	4 lines & 2 gears	Peak power	180W
Capacitor (Optional)	4μF/450V	Rotating speed	1200r/min
Stator	108*20	Weight	2.25kg
Packed QTY	12pcs/ctn		

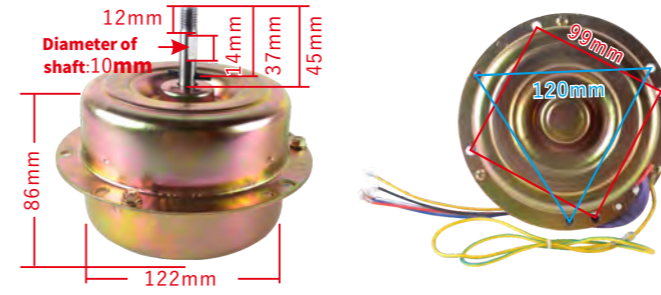

Model No. B19010013
Range Hood Motor-24mm 180w- whole sealing double bearing(Copper)

Product parameters			
Winding material	Copper winding	Working voltage	220v 50Hz
Number of lines	4 lines & 2 gears	Peak power	180W
Capacitor (Optional)	4μF/450V	Rotating speed	1200r/min
Stator	108*24	Weight	2.61kg
Packed QTY	12pcs/ctn		

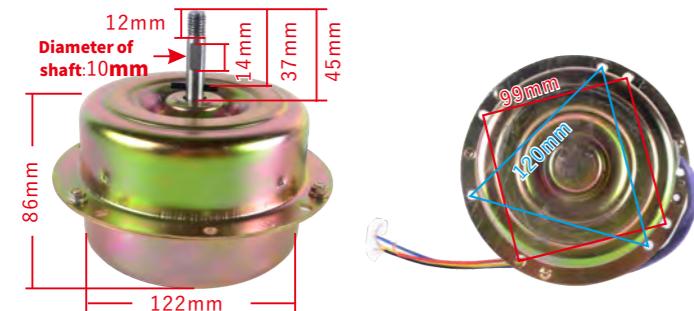

Model No. B19010030
Range Hood Motor-20mm 180w- whole sealing double bearing-(108Aluminum)

Product parameters			
Winding material	Aluminum winding	Working voltage	220v 50Hz
Number of lines	4 lines & 2 gears	Peak power	180W
Capacitor (Optional)	4μF/450V	Rotating speed	1200r/min
Stator	108*20	Weight	2.15kg
Packed QTY	12pcs/ctn		

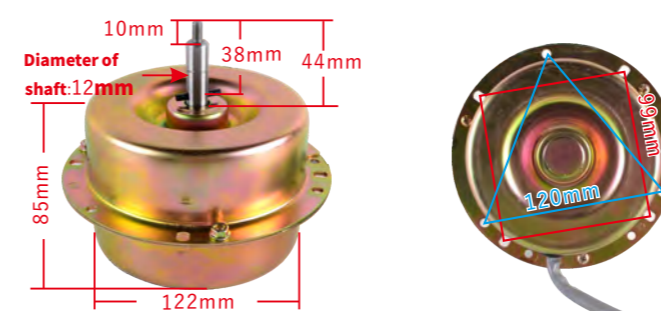

Model No. B19010001
Range Hood Motor-28mm 180w- whole sealing double bearing(Copper)(Fine wires)

Product parameters			
Winding material	Copper winding	Working voltage	220v 50Hz
Number of lines	5 lines & 2 gears	Peak power	180W
Capacitor (Optional)	6μF/450V	Rotating speed	1300r/min
Stator	108*28	Weight	3.05kg
Packed QTY	12pcs/ctn		

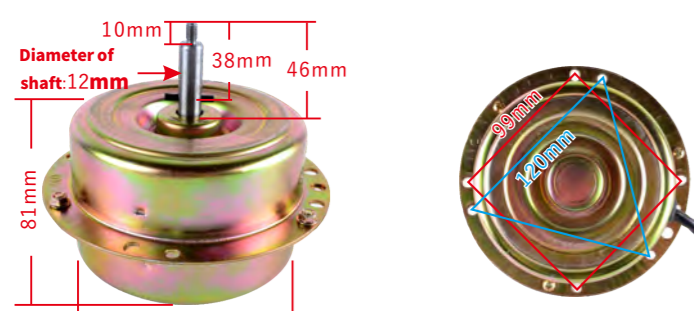

Model No. B19010020
Range Hood Motor-24mm 180w- whole sealing double bearing-(Fine wire)

Product parameters			
Winding material	Copper winding	Working voltage	220v 50Hz
Number of lines	4 lines & 2 gears	Peak power	180W
Capacitor (Optional)	4μF/450V	Rotating speed	1200r/min
Stator	108*24	Weight	2.45kg
Packed QTY	12pcs/ctn		

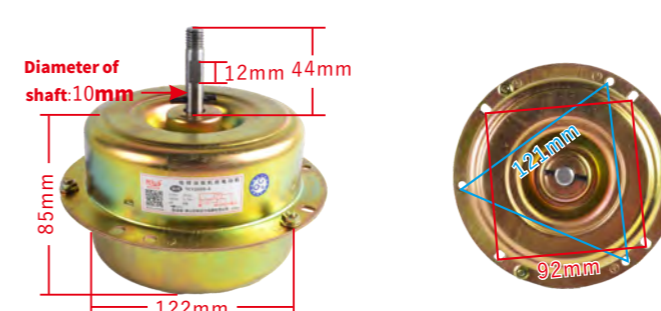

Model No. B19010064
Range Hood Motor-20mm 180w- whole sealing double bearing(Copper)

Product parameters			
Winding material	Copper winding	Working voltage	220v 50Hz
Number of lines	4 lines & 2 gears	Peak power	180W
Capacitor (Optional)	4μF/450V	Rotating speed	1200r/min
Stator	108*24	Weight	2.35kg
Packed QTY	12pcs/ctn		

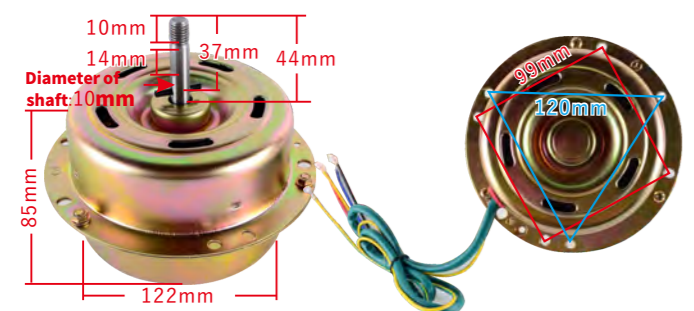

Model No. B19010005
Range Hood Motor-24mm 180w-Open pore double bearing(Copper)4 wire

Product parameters			
Winding material	Copper winding	Working voltage	220v 50Hz
Number of lines	4 lines & 2 gears	Peak power	180W
Capacitor (Optional)	4μF/450V	Rotating speed	1200r/min
Stator	108*24	Weight	2.36kg
Packed QTY	12pcs/ctn		

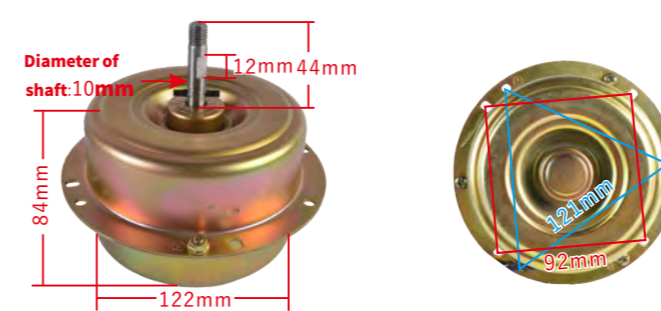

Model No. B19010065
Range Hood Motor-24mm 180w- whole sealing double bearing(Copper)

Product parameters			
Winding material	Copper winding	Working voltage	220v 50Hz
Number of lines	5 lines & 2 gears	Peak power	180W
Capacitor (Optional)	4μF/450V	Rotating speed	1300r/min
Stator	108*28	Weight	2.6kg
Packed QTY	12pcs/ctn		

Quality assurance of pure copper motor

- Full copper wire core, full torque.
- High quality double ball bearings energy saving and durable.
- Many styles, many choices.

Washing machine motor

Energy efficient
Durable
Silent

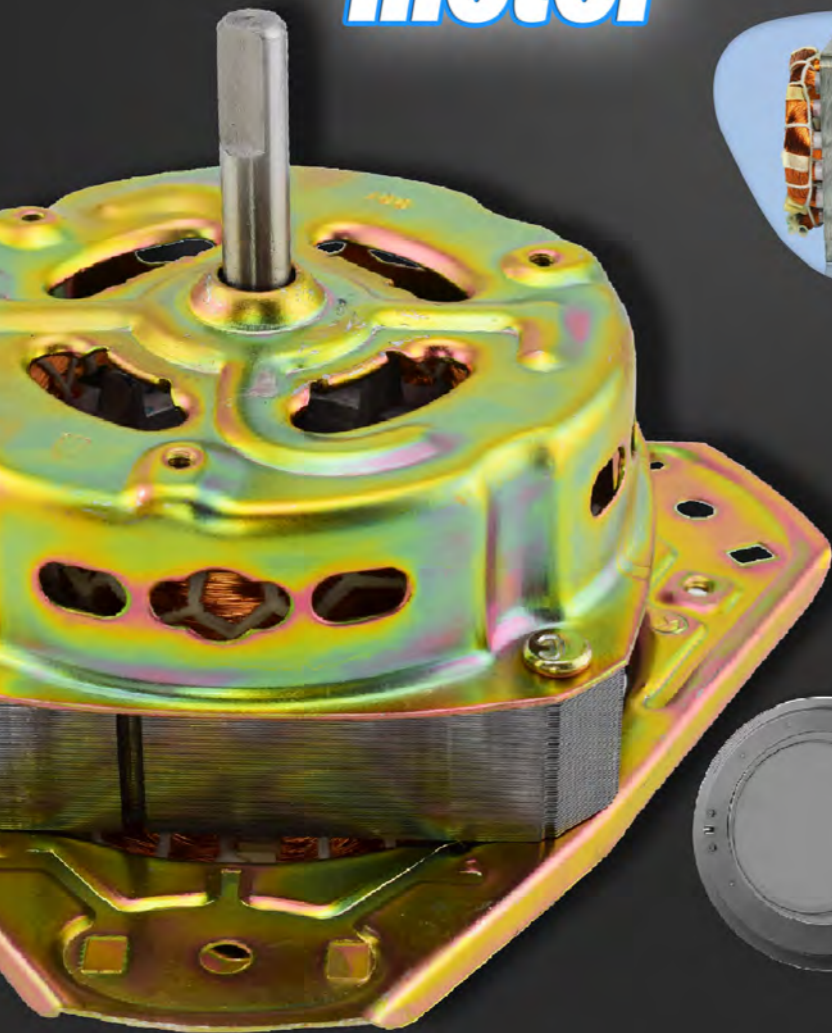

Model No. B03010009
Washing motor-150Wφ12-Suitable for Sharp-Copper wire

Product parameters	
Working voltage	220v 50Hz
Peak power	150W
Rotating speed	1280r/min
Capacitor	10μF/450V
Weight	3.11kg
Totation	Positive and Negative
Packed QTY	4 /6pcs/ctn

Model No. B03010003
Washing motor-150Wφ10-Suitable for Sharp-Copper wire

Product parameters	
Working voltage	220v 50Hz
Peak power	150W
Rotating speed	1280r/min
Capacitor	10μF/450V
Weight	3.11kg
Totation	Positive and Negative
Packed QTY	6 pcs/ctn

Model No. B03020083
Dewatering motor-80Wφ10-Suitable for Sharp-Copper wire

Product parameters	
Working voltage	220v 50Hz
Peak power	80W
Rotating speed	1350r/min
Capacitor	5μF/450V
Weight	2.23kg
Totation	Counter clock wise
Packed QTY	6 pcs/ctn

Model No. B03020058
Dewatering motor-80Wφ12-Suitable for Sharp-Copper wire

Product parameters	
Working voltage	220v 50Hz
Peak power	70W
Rotating speed	1280r/min
Capacitor	5μF/450V
Weight	2.23kg
Totation	Counter clock wise
Packed QTY	6 pcs/ctn

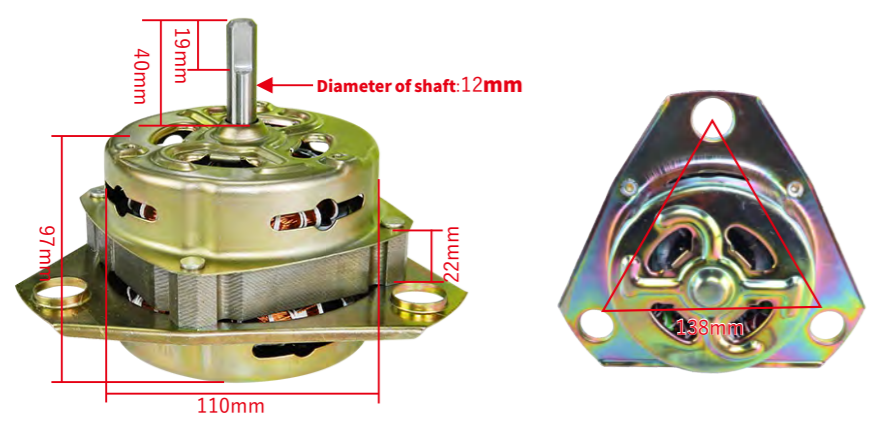

Model No. B03020048
Dewatering motor-80Wφ12
-Suitable for WEILI-Copper wire

Product parameters	
Working voltage	220v 50Hz
Peak power	80W
Rotating speed	1350r/min
Capacitor	5μF/450V
Weight	2.23kg
Totation	Counter clock wise
Packed QTY	6 pcs/ctn

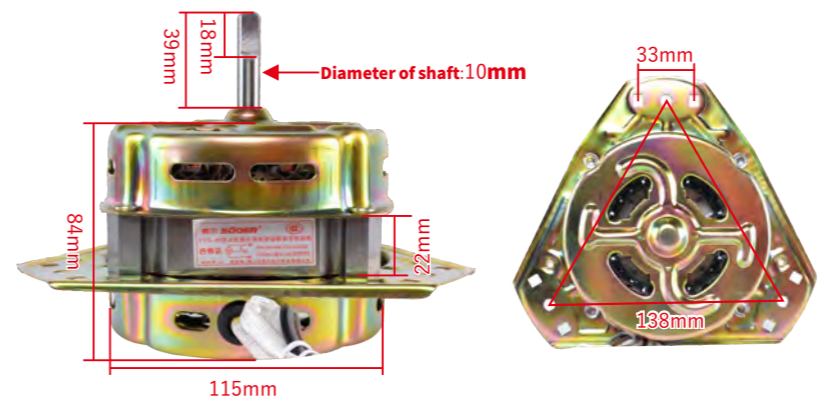

Model No. B03020053
Dewatering motor-80Wφ10
-Universal-Copper wire

Product parameters	
Working voltage	220v 50Hz
Peak power	80W
Rotating speed	1280r/min
Capacitor	5μF/450V
Weight	2.15kg
Totation	Counterclockwise
Packed QTY	6 pcs/ctn

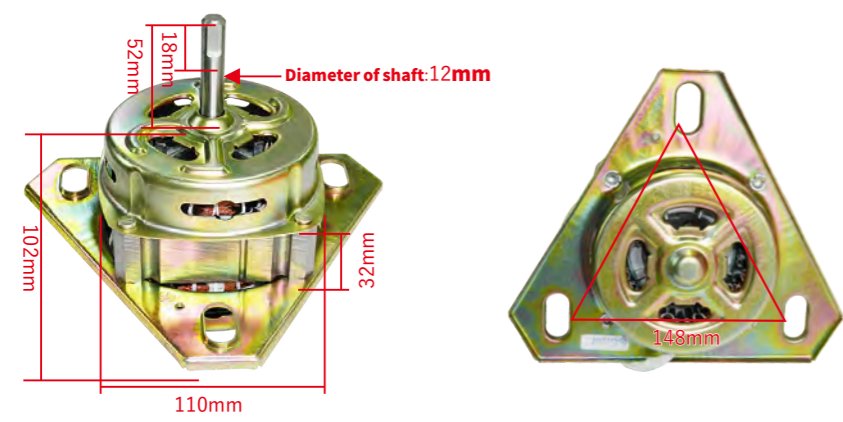

Model No. B03010021
Dewatering motor-150Wφ12-Suitable
for WEILI-Copper wire

Product parameters	
Working voltage	220v 50Hz
Peak power	150W
Rotating speed	1280r/min
Capacitor	10μF/450V
Weight	3.03kg
Totation	Positive and Negative
Packed QTY	6 pcs/ctn

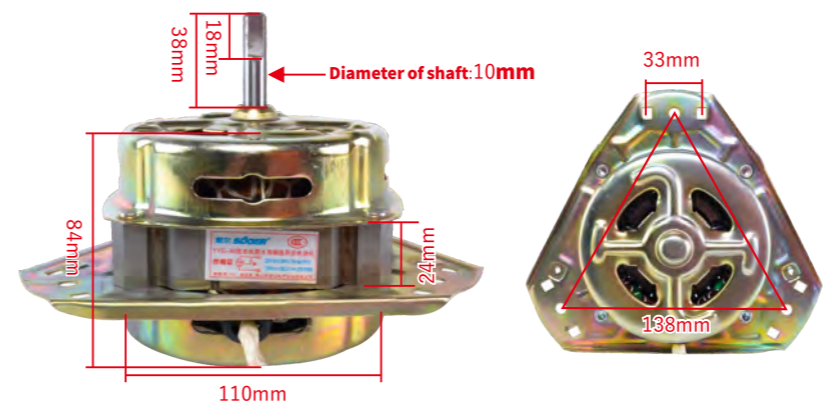

Model No. B03020075
Dewatering motor-90Wφ10
-Copper wire

Product parameters	
Working voltage	220v 50Hz
Peak power	90W
Rotating speed	1280r/min
Capacitor	6μF/450V
Weight	2.3kg
Totation	Counterclockwise
Packed QTY	6 pcs/ctn

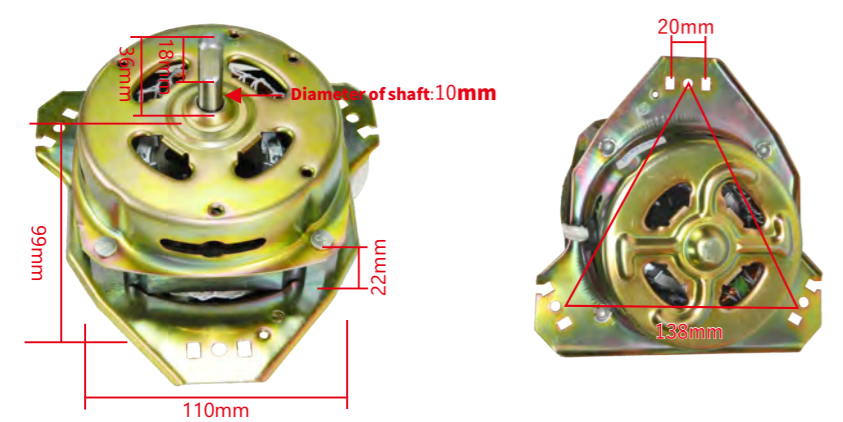

Model No. B03020004
Dewatering motor-80Wφ10
-Copper wire

Product parameters	
Working voltage	220v 50Hz
Peak power	80W
Rotating speed	1350r/min
Capacitor	5μF/450V
Weight	2.23kg
Totation	Counter clock wise
Packed QTY	6 pcs/ctn

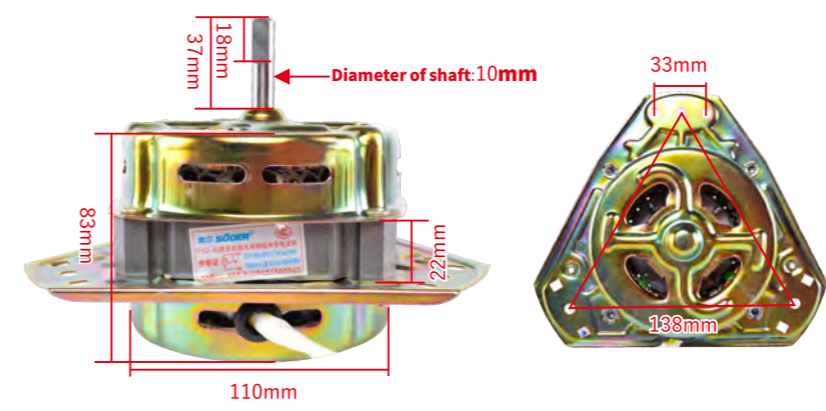

Model No. B03020077
Dewatering motor-80Wφ10
-Copper wire

Product parameters	
Working voltage	220v 50Hz
Peak power	80W
Rotating speed	1350r/min
Capacitor	5μF/450V
Weight	2.1kg
Totation	Counterclockwise
Packed QTY	6 pcs/ctn

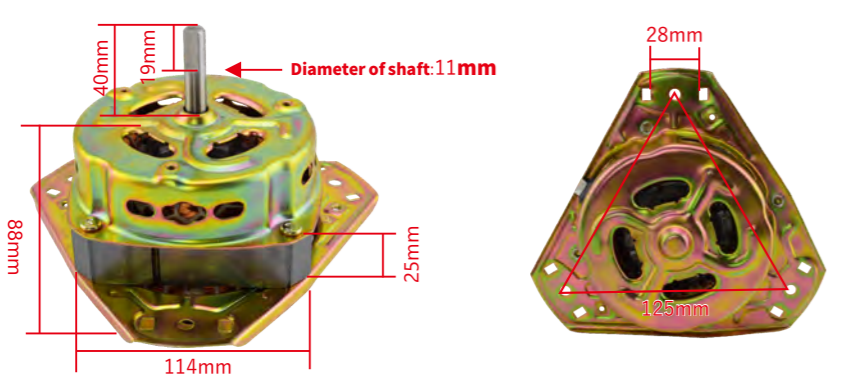

Model No. B03020178
Dewatering motor-100Wφ10
-Copper wire

Product parameters	
Working voltage	220v 50Hz
Peak power	100W
Rotating speed	1330r/min
Capacitor	6μF/450V
Weight	2.45kg
Totation	Counter clock wise
Packed QTY	12 pcs/ctn

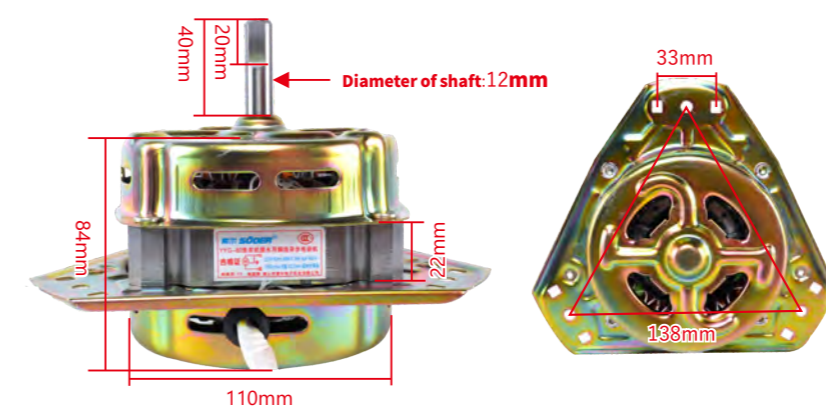

Model No. B03020081
Dewatering motor-80Wφ12
-Copper wire

Product parameters	
Working voltage	220v 50Hz
Peak power	80W
Rotating speed	1350r/min
Capacitor	5μF/450V
Weight	2.2kg
Totation	Counterclockwise
Packed QTY	6 pcs/ctn

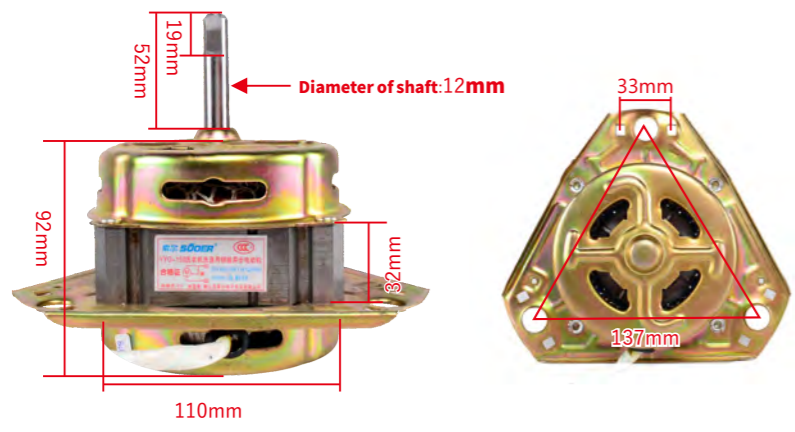

Model No. B19010002

Washing motor-150Wφ12
-General-Copper wire QS

Product parameters	
Working voltage	220v 50Hz
Peak power	150W
Rotating speed	1280r/min
Capacitor	10μF/450V
Weight	2.9kg
Totation	Positive and Negative
Packed QTY	6 pcs/ctn

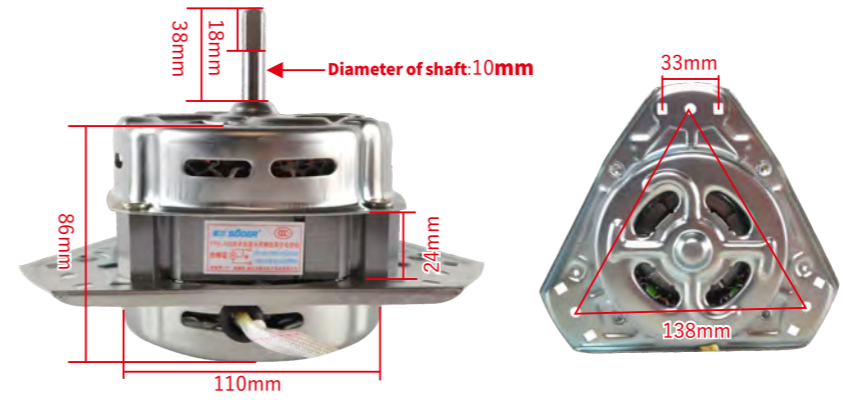

Model No. B03020118

Dewatering motor-100Wφ10-Universal
-White shell copper wire

Product parameters	
Working voltage	220v 50Hz
Peak power	100W
Rotating speed	1350r/min
Capacitor	6μF/450V
Weight	2.3kg
Totation	Counterclockwise
Packed QTY	6 pcs/ctn

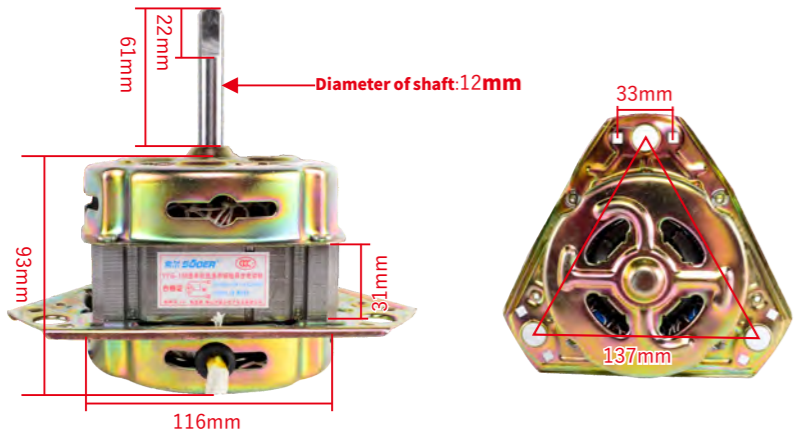

Model No. B03010102

Washing motor-150Wφ12-Universal
-(Shaft length 6CM)

Product parameters	
Working voltage	220v 50Hz
Peak power	150W
Rotating speed	1280r/min
Capacitor	10μF/450V
Weight	2.9kg
Totation	Positive and Negative
Packed QTY	6 pcs/ctn

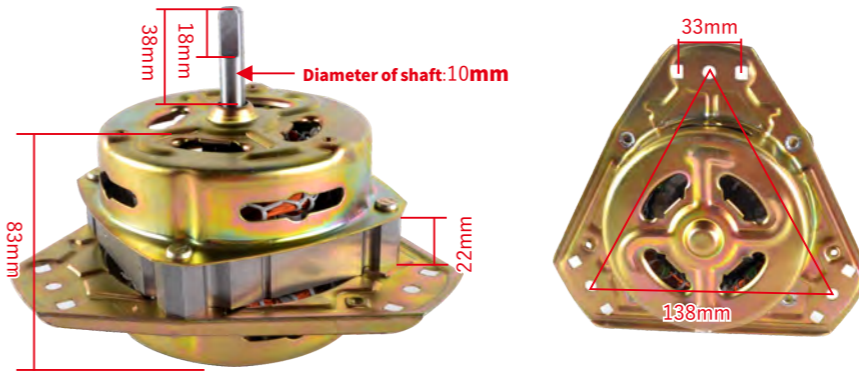

Model No. B03020122

Waterproof Offline-70Wφ10-Universal
-copper wire

Product parameters	
Working voltage	220v 50Hz
Peak power	70W
Rotating speed	1350r/min
Capacitor	5μF/450V
Weight	2.1kg
Totation	Counterclockwise
Packed QTY	6 pcs/ctn

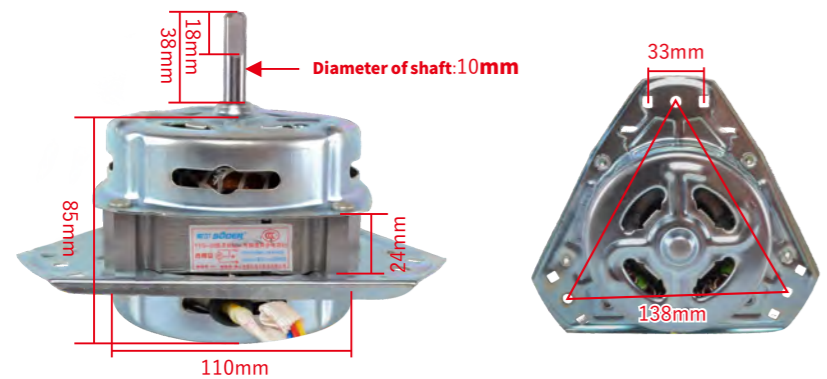

Model No. B03020036

Dewatering motor-90Wφ10-General
-White Shell Copper Wire

Product parameters	
Working voltage	220v 50Hz
Peak power	90W
Rotating speed	1280r/min
Capacitor	6μF/450V
Weight	2.3kg
Totation	Counter clock wise
Packed QTY	6 pcs/ctn

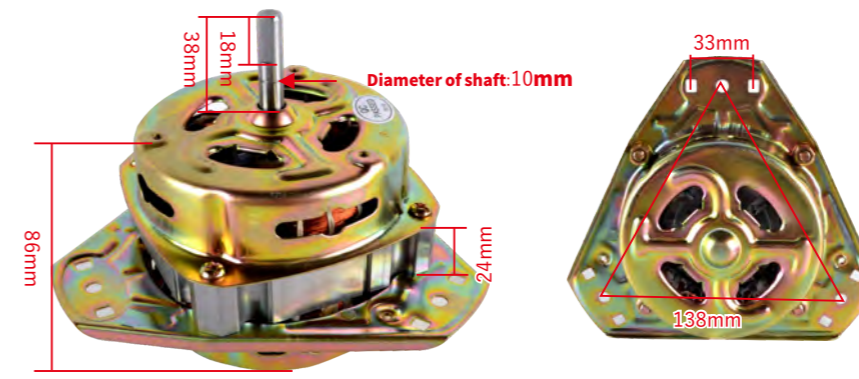

Model No. B03020130

Dewatering motor-90Wφ10-Universal
-copper wire

Product parameters	
Working voltage	220v 50Hz
Peak power	90W
Rotating speed	1430r/min
Capacitor	6μF/450V
Weight	2.4kg
Totation	Counterclockwise
Packed QTY	12 pcs/ctn

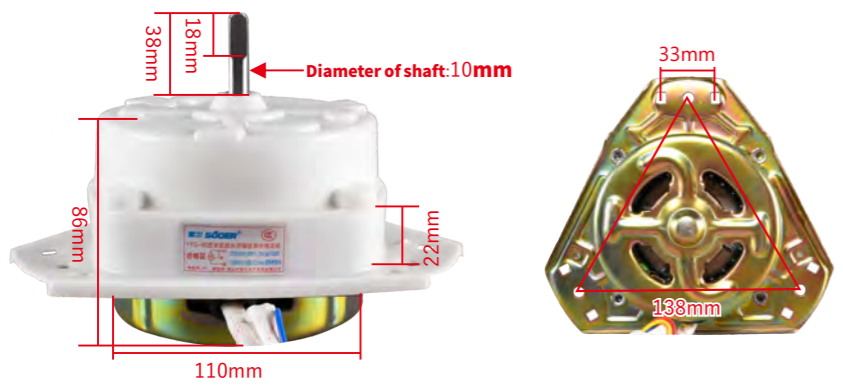

Model No. B03020050

Dewatering motor-80Wφ10-Universal
-Copper wire(Waterproof rubber cap)

Product parameters	
Working voltage	220v 50Hz
Peak power	80W
Rotating speed	1350r/min
Capacitor	5μF/450V
Weight	2.25kg
Totation	Counter clock wise
Packed QTY	6 pcs/ctn

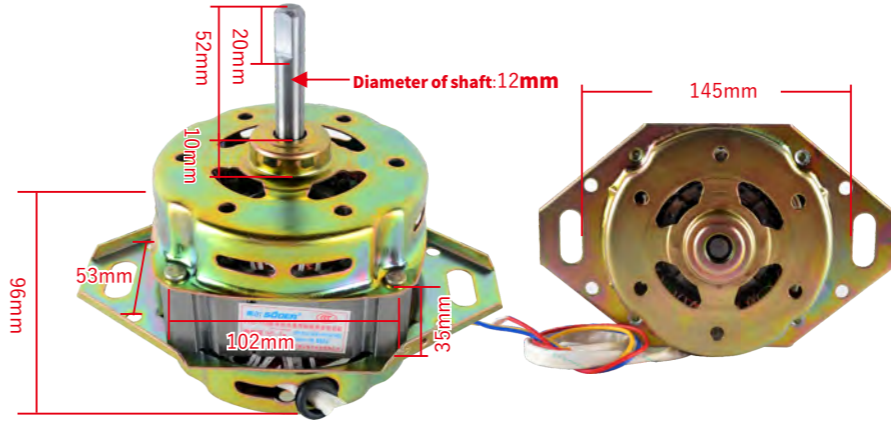

Model No. B03030005

Full automatic motor-150Wφ12-Copper
wire-Iron case

Product parameters	
Working voltage	220v 50Hz
Peak power	150W
Rotating speed	1280r/min
Capacitor	10μF/450V
Weight	2.25kg
Totation	Positive and Negative
Packed QTY	4 pcs/ctn

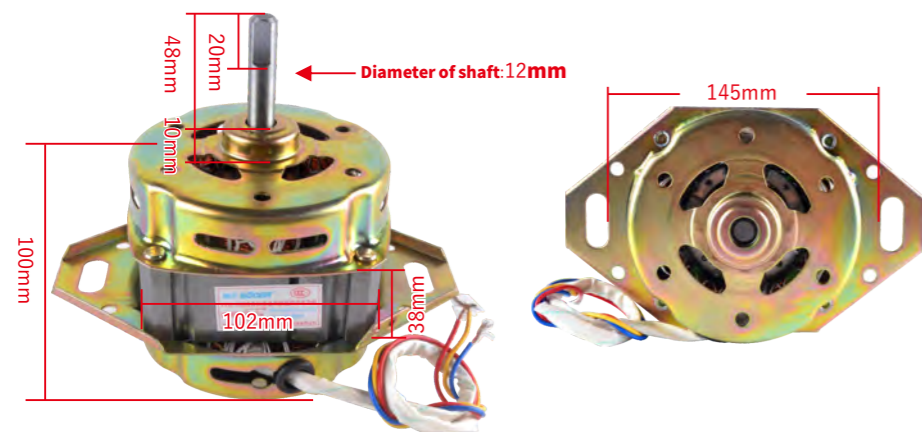

Model No. B03030016
Full automatic motor-180W ϕ 12-Copper wire-iron case

Product parameters	
Working voltage	220v 50Hz
Peak power	150W
Rotating speed	1280r/min
Capacitor	12 μ F/450V
Weight	3.61kg
Totation	Positive and Negative
Packed QTY	4 pcs/ctn

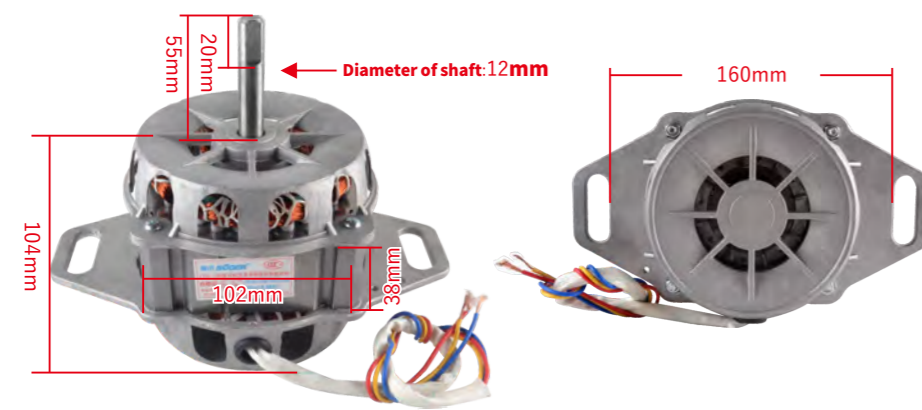

Model No. B03030009
Full automatic motor-180W ϕ 12-Copper wire-Aluminum shell (Foam bag)

Product parameters	
Working voltage	220v 50Hz
Peak power	180W
Rotating speed	1280r/min
Capacitor	12 μ F/450V
Weight	3.35kg
Totation	Positive and Negative
Packed QTY	4 pcs/ctn

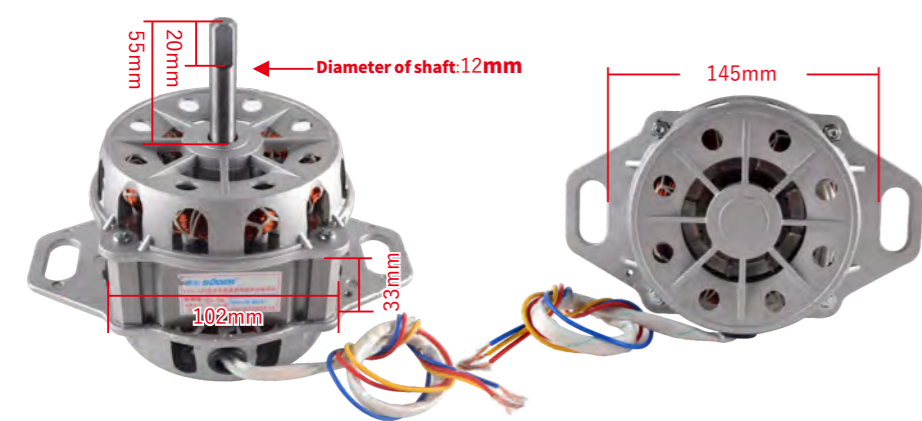

Model No. B03030017
Full automatic motor-180W ϕ 12-Copper wire-Aluminum shell (Foam bag)

Product parameters	
Working voltage	220v 50Hz
Peak power	180W
Rotating speed	1280r/min
Capacitor	12 μ F/450V
Weight	3.35kg
Totation	Positive and Negative
Packed QTY	4 pcs/ctn

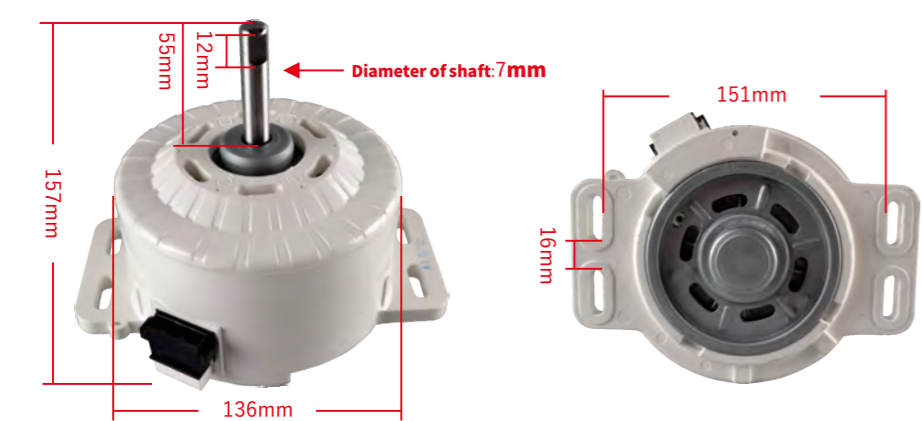

Model No. B03030018
Full automatic motor-180W ϕ 12 -Panasonic Plastic Sealing

Product parameters	
Working voltage	220v 50Hz
Peak power	180W
Rotating speed	1250r/min
Capacitor	13.5 μ F/450V
Weight	4.4kg
Totation	Positive and Negative
Packed QTY	1 pcs/ctn

FREEZER MOTOR

A variety of specifications for your choice

- 25W 30W
- 40W 60W
- 75W 90W



HIGH SPEED
SMOOTH OPERATION
POWER IS GREAT
LOW NOISE



HIGH QUALITY ROTOR

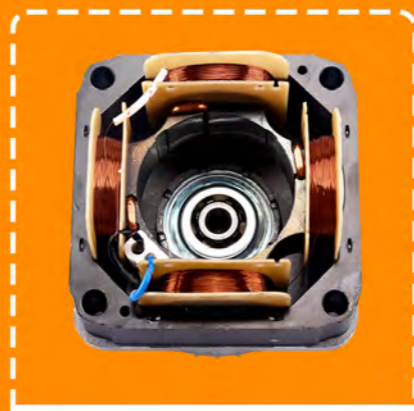

PURE COPPER COILS



Refrigerator & freezer Cooling motor

Aluminum ingot casting and one-time drilling

Efficient and stable

High compactness of motor components, more stable motor operation, zero error design, better efficiency

Thickened silicon steel sheet

Running smoothly

Can effectively protect the internal structure of the motor, ensure a fixed magnetic field to produce strong electromagnetic power, ensure that the motor structure is stable, and the smooth operation.

Open up and down aluminum case

Good heat dissipation performance

Open design to facilitate cross-flow ventilation good thermal performance, energy saving

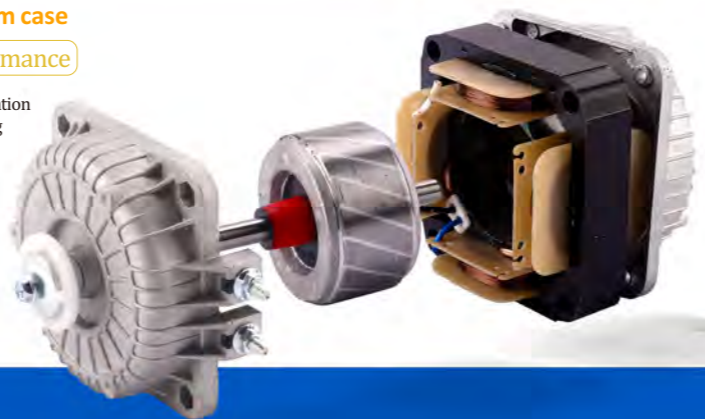

Copper coil

The core component of motor adopts high quality steel wire, high temperature resistance and durable. Being good in conductivity, low noise, high speed and good durability

Qualified rotor

The motor adopts new high-quality rotor, which can run smoothly with balance and help prolong service life of the motor.

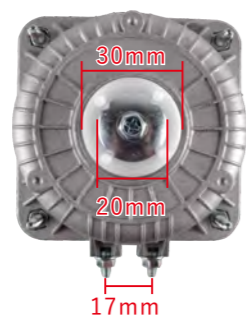

Model No. B02010013

Freezer motor-25W(Copper wire)

Product parameters

Winding material	Copper winding	Peak power	25W
Number of lines	2 lines	Rotating speed	1300r/min
Working voltage	220v 50/60Hz	Weight	0.75kg
Packed QTY	24 pcs/ctn		

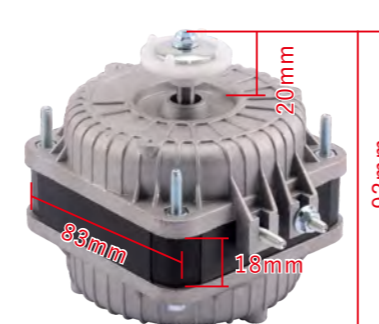

Model No. B02010016

Freezer motor-40W(Copper wire)

Product parameters

Winding material	Copper winding	Peak power	40W
Number of lines	2 lines	Rotating speed	1300r/min
Working voltage	220v 50/60Hz	Weight	1kg
Packed QTY	24 pcs/ctn		

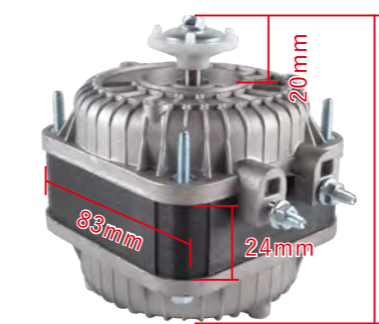

Model No. B02010017

Freezer motor-60W(Copper wire)

Product parameters

Winding material	Copper winding	Peak power	60W
Number of lines	2 lines	Rotating speed	1300r/min
Working voltage	220v 50/60Hz	Weight	1.25kg
Packed QTY	12 pcs/ctn		

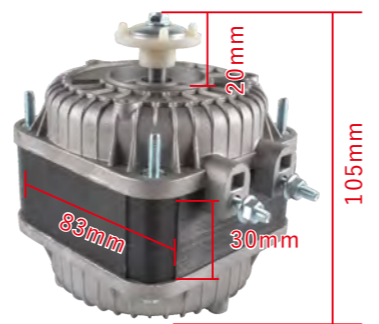

Model No. B02010018

Freezer motor-75W(Copper wire)

Product parameters

Winding material	Copper winding	Peak power	75W
Number of lines	2 lines	Rotating speed	1300r/min
Working voltage	220v 50/60Hz	Weight	1.45kg
Packed QTY	12 pcs/ctn		

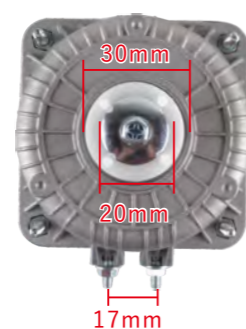

Model No. B02010014

Freezer motor-30W(Copper wire)

Product parameters

Winding material	Copper winding	Peak power	30W
Number of lines	2 lines	Rotating speed	1300r/min
Working voltage	220v 50/60Hz	Weight	0.75kg
Packed QTY	24 pcs/ctn		

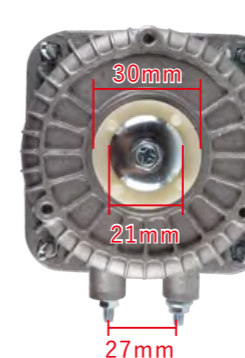
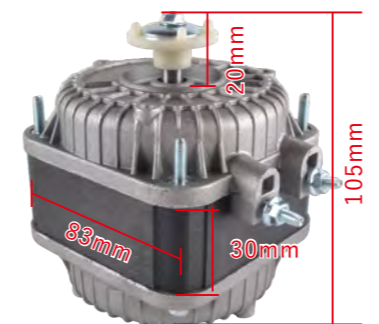

Model No. B02010019

Freezer motor-90W(Copper wire)

Product parameters

Winding material	Copper winding	Peak power	75W
Number of lines	2 lines	Rotating speed	1300r/min
Working voltage	220v 50/60Hz	Weight	1.5kg
Packed QTY	12 pcs/ctn		

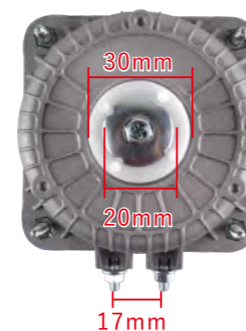

Model No. B02010015

Freezer motor-35W(Copper wire)

Product parameters

Winding material	Copper winding	Peak power	35W
Number of lines	2 lines	Rotating speed	1300r/min
Working voltage	220v 50/60Hz	Weight	0.75kg
Packed QTY	24 pcs/ctn		

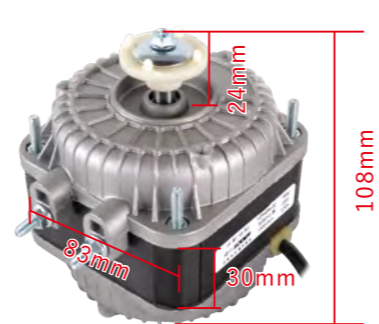

Model No. B02010055

Freezer motor-75W(Copper wire)(3 screw holes)

Product parameters

Winding material	Copper winding	Peak power	75W
Number of lines	2 lines	Rotating speed	1300r/min
Working voltage	220v 50/60Hz	Weight	1.5kg
Packed QTY	24 pcs/ctn		